

OPERATION MANUAL



RF Reader
Leser8_7
Leser 7 Plus



The Leser8_xx is available in various hardware and firmware versions.
The version 7 Plus corresponds to the previous Leser 7,
i.e., it is function compatible to Leser 7

Important! Read by all means!

To maintain the perfect shipping conditions and to ensure safe operation please observe the instructions in this Operation Manual. Damages caused by non-observance of these instructions will invalidate any guarantee. We further cannot take liability for any consequential damages.

Table of contents

	page
1 Introduction	3
2 Intended Use	3
3 Safety Instructions.....	3
4 Device Description	4
5 Functional Description	5
6 Connections	5
7 Putting into Operation	5
8 RS 232 Settings:	6
9 General Serial Protocol	6
9.1 Format of commands.....	6
9.2 Response format.....	6
9.3 Useful ASCII codes and checksum calculation:	6
9.4 Addressing the reader	7
10 Commands Leser 7	7
10.1 Commands.....	7
10.1.1 Hello (H)	7
10.1.2 Load (L)	7
10.1.3 Save (S)	7
10.1.4 Command (C)	7
10.2 Subcommand Groups for Load (L) und Save (S)	8
10.2.1 Parameter 16bit (P)	8
10.2.2 Transponder (T)	10
10.2.3 Time window for access (Z)	10
10.2.4 Event memory (E)	11
10.2.5 Serial number (S).....	12
10.2.6 clock (U)	12
10.3 Subcommandgroups for Command (C)	13
10.3.1 Relay (R).....	13
10.3.2 Head (H)	13
10.3.3 Transponder number (T).....	13
11 Application Examples	14
12 Care, Maintenance and Disposal	15
13 Debugging.....	15
14 Technical Specifications.....	15
15 Notes on Manufacturer	15

1 Introduction

Dear Customer,

We want to thank you for purchasing this Standalone Reader.

With this unit you have acquired a product built to the latest state of engineering. Its operation is simple and easily understood. Nevertheless please read this Operation Manual carefully for optimum utilization of all of its features.

2 Intended Use

The intended use of this Standalone Reader is the acquisition of transponder data by use of an Antenna Module. These data will be compared by the Standalone Reader with the transponder data stored in an internal EEPROM. If any one of the stored transponder numbers is recognized the Reader will switch an output. Any use other than the one pointed out above is not admissible.

Design and construction of this Module correspond to all European and national requirements for Electro Magnetic Compatibility (EMC). The unit carries the CE-Sign, the conformity has been proven. All appropriate commentaries and records are in the possession of the manufacturer.

3 Safety Instructions

Important Informations on the Reader Module:

- In conjunction with the Reader Module the Antenna builds a tank circuit creating high voltage at the antenna terminals. Please avoid any contact to these antenna terminals during operation of the Reader and especially keep children at a safe distance from the device.
- The RF Reader Family has not been designed to safely lock or secure doors. During prolonged absence from any room made accessible by a Reader the door must therefore further be locked by means of the original key.
- In order to guarantee sabotage safe operation do in any case mount the Reader's electronic circuit - unreachable for non-authorized persons - inside of the building.
- We cannot take liability for damages caused by improper and/or careless handling of RF Reader products.

Notes on Installation of the Reader Modules:

- The Modules are considered Reading and Controlling Devices of Mode of Operation Typ 1 according to EN 60730 (VDE 0631).
- When installing the Reader and Antenna Modules ensure a clean and dry environment.
- The individual Modules must be dry and free of dust.
- For protection of the power supply line use a slow-acting 2.5 A fuse.
- In case a bell transformer is used to provide the necessary power to the Reader Modules of the RF Reader it has to correspond with the requirements according to EN 61558-2-8 (DIN VDE 0570 Part 2-8: Special requirements for bell and ringer transformers).

Notes on Placing and Mounting the Reader Modules:

When mounting Reader and Antenna the following guidelines have to be observed:

- Metallic objects must not be placed between Antenna and Transponder.
- The Antenna should be mounted on non-metallic material (wood, concrete) at a minimum distance of 3 cm from any metallic object.
- The connecting line of the Antenna must not be of any length in excess of 1.5 m. Otherwise the reading distance stated for the Reader Modules cannot be guaranteed.
- The connecting line of the Antenna must not be mounted in the immediate proximity of any other line carrying electric current.
- Two or more connecting lines of any Antennas must not be mounted side by side.
- **When mounting several RF Readers inferences of Modules among each other can be avoided if a minimum distance of approximately 1 m is kept between Reading devices.**

4 Device Description

The Rf reader Leser 8_7 is a stand alone reader used for access to doors, garage doors or access to machines. By means of the on board relay you can directly switch door openers. For opening garage doors the reader has an extended supply voltage range of up to 30 V. Under item **12. Application examples** you can find more detailed examples for above applications.

The RF reader Leser8_7 is a versatile device for activating various machines or other electrical devices. With its adjustable output switch time from 0,5 seconds up to 127 minutes and its selectable ON/OFF mode you can flexibly set the reader to control and monitor the access to your rooms or machines.

PCB RF reader Leser 7

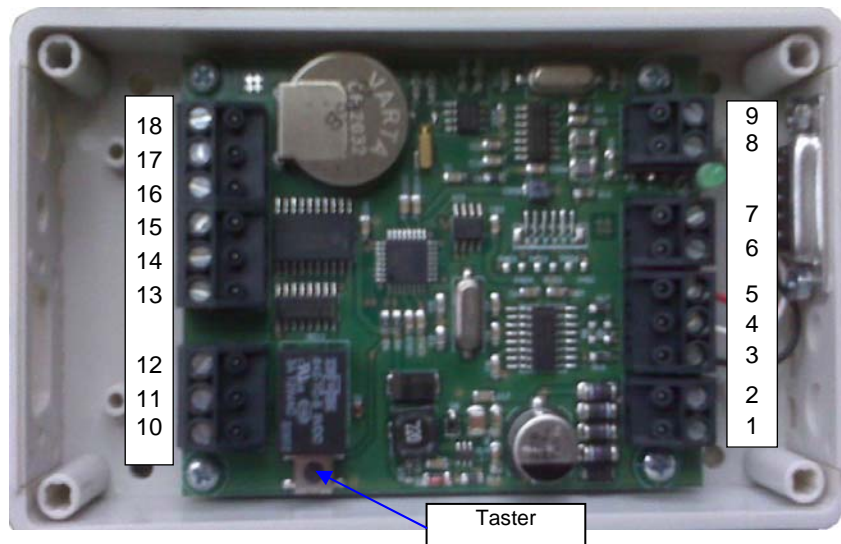

Terminal positions:

1. AC2 (7 to 30V DC, 7 to 20V AC)
2. AC1 (7 to 30V DC, 7 to 20V AC)
3. GND for RS232
4. RX (connect to TX of PC)
5. TX (connect to RX of PC)
6. GND (for external push-button)
7. Push-button input (connected to 5V with pull up resistor of app. 5k)
8. ANT2
9. ANT1

10. Relay NC (normally closed)
11. Relay NO (normally open)
12. Relay COM
13. VIN (output power for OpenCollector-outputs)
14. OUT6 (OpenCollector output, max 200 mA)
15. OUT5 (OpenCollector output, max 100 mA)
16. OUT4 (OpenCollector output, max 100 mA)
17. OUT3 (OpenCollector output, max 100 mA)
18. OUT2 (OpenCollector output, max 100 mA)

Attention: On version Leser7 Plus all OC outputs are switched in parallel to the relay.

5 Functional Description

The RF reader Leser8_7 with serial RS232 interface and RTC is a RF reader, which can be used both as a stand-alone reader or as a reading head just sending the decoded transponder numbers to the PC.

Up to 100 transponder numbers with appropriate "PERMITTED" time windows, as well as up to 2500 reading events with transponder number, date and time can be stored in an on board EEPROM.

If a decoded transponder is stored in the memory and the actual reader time does match with the preset "PERMITTED" time window of this transponder, the reader switches an output and registers this event in a separate event memory.

The LED on the pcb does show the decoding of any appropriate transponder, even if it is currently not permitted to switch the output.

Through the serial interface and the PC software "LeserPlus Manager" the table of permitted transponders and the time windows can be comfortably managed: uploaded, modified and downloaded to the reader. The registered events can be uploaded to the PC providing a complete history of access events.

Further a variety of configuration bits can be set, as well as the switch time of the output from 0,5 sec up to 127 min.

A more detailed description of the reader is available in item **Operation**.

6 Connections

The exact terminal positions can be seen in the table in Section 4. **Device Description** above.

The reader can be operated from 7 to 30V DC or from 7 to 20V AC voltage.

Current consumption is typ. below 50 mA in normal operation and app. 75 mA during switching the relay output.

7 Putting into Operation

After the Leser8_7 and the Antenna have been connected in accordance with the connection scheme the Leser 7 can be put into operation.

If you are using the PC software, please connect the serial interface of the reader with the corresponding pins of the RS232 interface of your PC.

After activating the power supply the Reader is in permanent Reading Mode.

The proper configuration of the reader, i.e. setting the configuration bits, setting the switch time and storing the transponder numbers and time windows has to be done with the PC software "Leser Plus Manager".

More details can be read in items 8 to 11.

8 RS 232 Settings:

For communication with the reader the standard RS232 protocol has to be used. Following interface parameters have to be set:

Baudrate: **57600**
 Databits: **8**
 Stopbits: **1**
 Parity: **none**

9 General Serial Protocol

9.1 Format of commands

All commands to the reader are based on following basic format:

<STX><ADR><COMMAND><SUBCOMMAND><INDEX><DATA><CRC><EOT>

<STX>	ASCII Code 2	Start of Text
<EOT>	ASCII Code 4	End of Transmission
<INDEX>	2 Byte (4 ASCII characters) as additional parameters	

9.2 Response format

The reader responds to commands with one of the following formats:

- Response to a successful command
<STX><ADR><COMMAND><SUBCOMMAND><ACK><CRC><EOT>
- Response to a failing command
<STX><ADR><COMMAND><SUBCOMMAND><NAK><CRC><EOT>
- Response to an incorrect command
<STX><ADR><NAK><CRC><EOT>
- Response to a command requesting data from the reader
<STX><ADR><COMMAND><SUBCOMMAND><DATA><CRC><EOT>

9.3 Useful ASCII codes and checksum calculation:

<ACK>	ASCII Code 6	Acknowledge
<NAK>	ASCII Code 15	Not Acknowledge

All hex coded numbers shall be in capital letters (0A and not 0a).

The checksum (**<CRC>**) shall be calculated as cross total of the transmitted ASCII characters without **<STX>** und **<EOT>**.

The CRC itself shall also be sent as ASCII characters.

Example: command to be sent: **<STX>SP000100FA<CRC><EOT>**

Cross total of S + P + 0 + ... in Hexadecimal (0x53 + 0x50 + 0x30 + 0x30 + 0x30 + 0x31 + 0x30 + 0x30 + 0x46 + 0x41 = 0x024B)

Only the lower 8 bit of the cross total shall be sent, so 0x024B → 4B

The resulting checksum is 4B.

Resulting command: **<STX>SP000100FA4B<EOT>**

9.4 Addressing the reader

The address of a reader (<ADR>) is the byte 0 of the serial number. Independent of the readers address the reader responds to commands with address **FF**. The reader address is currently of no use and designated for later use only.

10 Commands Leser8_7

There are two types of commands:

- <COMMAND> General command
- <SUBCOMMAND> subcommands of a general command

Commands and subcommands have to be sent as ASCII characters only.

10.1 Commands

10.1.1 Hello (H)

Description: Provides the product code and version of the reader
(This command must not have a CRC)
Reader response shall be XRDVab.
a = Firmware version
b = Hardware version

Format: <STX><ADR>H<EOT>

Example: <STX>FFH<EOT>
 <STX>XRDV18AD<EOT>

10.1.2 Load (L)

Description: Uploads data or settings from the reader to the PC.

Format: <STX><ADR>L<SUBCOMMAND><INDEX><CRC><EOT>

10.1.3 Save (S)

Description: Downloads and stores data or settings from the PC to the reader.

Format: <STX><ADR>S<SUBCOMMAND><INDEX><DATA><CRC><EOT>

10.1.4 Command (C)

Description: Control command for the reader

Format: <STX><ADR>C<SUBCOMMAND><DATA><CRC><EOT>

10.2 Subcommand Groups for Load (L) und Save (S)

10.2.1 Parameter 16bit (P)

Description: Configuration of the reader with a 16 bit parameter. The bits 8 to 15 are currently not used. However always 16 bit shall be sent to the reader.

Format: <STX><ADR>LP<INDEX><CRC><EOT>
<STX><ADR>SP<INDEX><DATA><CRC><EOT>

- Index 0000

Reader Configuration bits:

Bit	Value 1	Value 0	Configuration
7	enable	disable	Send Event
6	enable	disable	Push button Tag 0
5	enable	disable	Push button Relay off
4	enable	disable	Switch relay
3	in/out	Minute	Storage Mode
2	enable	disable	Store non permitted
1	enable	disable	Auto off / Retrigger
0	on/off	Pulse	On/Off or pulse mode

Description of the config bits:

Bit 7: If this bit is set, every event shall be immediately sent on the serial interface

Bit 6: If this bit is set, the reader performs on pushing the push button, as if the transponder of memory space 0 would have been read. This is important, if you want to see in the event records, that start or end of an access trial has been started by push button. For this you can store on memory space 0 a (also virtual) transponder number, which is easily visible in the event records. This bit must not be set in parallel to bit 5.

Bit 5: By setting this bit, the relay can be manually switched off by pushing the push button. This can be advantageous, if a long switch time has been set, but the relay should be switched off before this switch time has passed. In the event records this event will be stored with transponder number 0 (as well as the AUTO/OFF event).

This bit must not be set in parallel to bit 6.

Bit 4: This bit activates the relay output.

If you do not want the relay switching at reading of a valid transponder number this bit must be set to 0.

Bit 3: With this bit you can set the mode of how events are recorded in the event table:

Bit 3 set to 0 -> Minute mode:

Every event will be stored with a minute resolution. If a transponder should be kept close to the antenna for a longer time period, then every minute a new event entry will be generated. In this case it is more advantageous to use the IN/OUT mode.

Bit 3 set to 1 -> IN/OUT mode:

If bit 3 is set, only events will be recorded which change the status of the reader. This means, if a transponder is kept for a long time close to the antenna, only the point of entry and the point of removal will be recorded in the event table. In the ON/OFF mode the time of switching the relay on and switching it off will be recorded.

Bit 2: By setting bit 2 all events will be recorded in the event table, even those which are caused by not permitted transponders. Otherwise only permitted transponder will be recorded.

In case of noise in the environment of the antenna it might be possible, that the noise is decoded as not permitted transponder. Please deactivate this bit for avoiding memory overflow in the event table by noise generated entries.

Bit 1: The meaning of this bit depends on the status of bit 0.

- If bit 0 is set to 0 (pulse mode), then with bit 1 retrigger can be activated or deactivated. In case retrigger is activated (bit 1 set to 1), the switch time of the relay will be counted from the point of time, at which the transponder is removed from the antenna. If a transponder is held to the antenna before the switch time is passed, it will be prolonged. If the bit 1 is set to 0, the switch time will end independent of how long the transponder has been kept close to the antenna and no prolongation will be the case if a transponder again will be put close to the antenna before the switch time has passed.
- If bit 0 is set to 1 (ON/OFF mode) the with bit 1 the AUTO/OFF function can be set. With bit 1 set to 1 the relay switches off after the switch time has passed. With bit 1 set to 0 the relay stays on continuously until a valid transponder switches the output off.

Bit 0: With bit 0 you can select the pulse mode (bit 0 =0) or the ON/OFF mode (bit 0 = 1).

The pulse mode means that the output switches off after the switch time has passed.

The ON/OFF mode means that the output stays on until a valid transponder switches the output off (or AUTO/OFF is activated, see bit 1 or by push button, see bit 5).

example:

command: **<STX>FFLP0000E8<EOT>**

response: **<STX>FFLP00B2FC<EOT>**

The configuration byte is B2, i.e. 1011 0010

bit 7 on, bit 6 off, bit 5 on, bit 4 on,

bit 3 off, bit 2 off, bit 1 on, bit 0 off,

meaning see above

- Index 0001

setting the switch time

The accuracy of the set time is depending of the value. If seconds are set, the actual switch time can differ from the set time by a few seconds. Only if minutes are set the switch time is precise (this is the case due to different timers being used).

Bit 0-6 switch time in seconds or minutes

Bit 7 value 0 → seconds / value 1 → minutes

Attention: If the switch time is set to seconds, then value 1 stands for 0,5 sec, value 2 for 1 sec, value 3 for 2 sec, and so on. There are no 0,5 sec steps above 1 sec.

example: the value 30 means 29 sec, if bit 7 is set to 0 and 30 minutes if bit 7 is set to 1.

- Index 0002 number of stored transponders
 Leser 7 → max. 100 transponders

- Index 0003 Event Pointer
 Points to the latest stored event.
 Events are stored cyclically. If the event pointer is at its
 maximum it starts at 0 again and overwrites the oldest
 events.
 Leser 7 → max. 2500 events

10.2.2 Transponder (T)

description: loads the transponder number from the memory of the reader or stores the transponder number into the memory. The transponder number is shown as a 10 digit HEX number in ASCII code (e.g. AC3F00D1B4).

Format: <STX><ADR>LT<INDEX><CRC><EOT>
 <STX><ADR>ST<INDEX><DATA><CRC><EOT>

example: command: <STX>FFLT00A2FF<EOT>
 response: <STX>FFLTA9200620BD56<EOT>

reads the transponder number A9200620BD from the memory place 00A2h, i.e. the 162nd position.

10.2.3 Time window for access (Z)

description: With this comand the reader will be configured, during which time periods a transponder shall have access. You can set the week days and 4 time windows per transponder. The data have a length of 5 bytes (10 ASCII characters).

Format: <STX><ADR>LZ<INDEX><CRC><EOT>
 <STX><ADR>SZ<INDEX><DATA><CRC><EOT>

Dataformat: [weekdays][MIN(from)][HRS(from)][MIN(til)][HRS(til)]

1. Byte: weekdays (Bit 0 always set to 0)

Bit 7	Bit 6	Bit 5	Bit 4	Bit 3	Bit 2	Bit 1	Bit 0
So	Sa	Fr	Do	Mi	Di	Mo	0

2. Byte: minutes (from) BCD coded

Bit 7	Bit 6	Bit 5	Bit 4	Bit 3	Bit 2	Bit 1	Bit 0
decade of minutes				single minutes			

3. Byte: hours (from) BCD coded

Bit 7	Bit 6	Bit 5	Bit 4	Bit 3	Bit 2	Bit 1	Bit 0
decade of hours				single hours			

4. Byte: minutes (til) BCD coded

Bit 7	Bit 6	Bit 5	Bit 4	Bit 3	Bit 2	Bit 1	Bit 0
decade of minutes				single minutes			

5. Byte: hours (til) BCD coded

Bit 7	Bit 6	Bit 5	Bit 4	Bit 3	Bit 2	Bit 1	Bit 0

decade of hours	single hours
-----------------	--------------

example: command: <STX>FFSZ0006FE3008451625<EOT>
 response: <STX>FFSZ<ACK>3F<EOT>

stores following time windows:
 Index 0006 → 3rd time window of transponder at 2nd place
 FE → all weekdays permitted
 3008 → from 08:30
 4516 → til 16:45

Attention: As per transponder 4 time windows are possible the index counting of the time windows is modulo 4 related to transponders. Time window index 0000 to 0003 belong to transponder 1, index 0004 to 0007 to transponder 2, 0008 to 000B to transponder 3, and so on.

10.2.4 Event memory (E)

description: With this command the event memory can be read.

Format: <STX><ADR>LE<INDEX><CRC><EOT>

response: [Transp. number][MIN][HRS][access rights and DAY][Event and MONTH][YEAR]

Byte access rights and DAY:

Bit 7	Bit 6	Bit 5	Bit 4	Bit 3	Bit 2	Bit 1	Bit 0
Access rights see table below		day		day			
		decade		single			
6 Bit for the day (BCD coded)							

Meaning		
0	0	Access denied
1	0	Access permitted
0	1	Access temporarily denied (out of time window)

Byte Event und MONTH:

Bit 7	Bit 6	Bit 5	Bit 4	Bit 3	Bit 2	Bit 1	Bit 0
Switch event (see table below)			Month	Month			
			decade	Single			
5 Bit month (BCD coded)							

Meaning of switch event			
0	0	1	Relay unchanged
0	1	1	Relay switched on
1	0	1	Relay switched off
0	1	0	Transponder detected
1	1	0	Transponder kept in field
1	0	0	Transponder removed

example: **<STX><FF>LE300DB10090541169D00442<EOT>**
 300DB10090 Transpondernummer
 5411 = 11:54
 69 = 01 10 1001 = 01 access temp. denied, 10 1001 = 2 9 for 29th day
 D0 = 110 1 0000 = 110 Transponder kept in field; 1 0000 = 10 for October
 04 = year 04
 42 = CRC

10.2.5 Serial number (S)

description: With this command the serial number can be read or set.

Attention: the 1st byte of the serial number is used as address of the reader. Index has always to be 0000.

Format: **<STX><ADR>LS<INDEX><CRC><EOT>**
<STX><ADR>SS<INDEX><DATA><CRC><EOT>

Dataformat: The serial number has to have 20 characters (10 bytes).

example: command: **<STX>FFLS0000EB<EOT>**
 response: **<STX>FFLSFF12345678901234567868<EOT>**
 reads the serial number FF123456789012345678 from the reader. I.e., the address of this reader is FF (first byte).

10.2.6 clock (U)

description: This command is used for setting and reading the clock data.

Achtung: Index is always 0000.

Format: **<STX><ADR>LU<INDEX><CRC><EOT>**
<STX><ADR>SU<INDEX><DATA><CRC><EOT>

Dataformat: Time and date are shown in following format:

ssmmhhWWDDMMYY

ss → seconds 2 digits
 mm → Minutes 2 digits
 hh → hours 2 digits
 WW → weekday (01 = Monday, 02 = Tuesday, 03 = Wednesday, 04 = Thursday, 05 = Friday, 06 = Saturday, 07 = Sunday)
 DD → day 2 digits
 MM → months 2 digits
 YY → year 2 digits

Beispiel: command: **<STX>FFLU0000ED<EOT>**
 response: **<STX>FFLU05441301030105E8<EOT>**
 reads the time 13:44:05 on Monday, 03.01.05. (3rd of Jan. 05)

10.3 Subcommand Groups for Command (C)

10.3.1 Relay (R)

description: This command is used for switching the relay on and off.
value 1 means relay on
value 0 means relay off

Format: `<STX><ADR>CR<DATA><CRC><EOT>`
example: command: `<STX>FFCR152<EOT>`
response: `<STX>FFCR<ACK>27<EOT>`
switches the relay on

command: `<STX>FFCR051<EOT>`
response: `<STX>FFCR<ACK>27<EOT>`
switches the relay off >

10.3.2 Head (H)

description: With this command you can activate and deactivate the reading head mode.
value 1 means reading head mode
value 0 means stand alone mode

Format: `<STX><ADR>CH<DATA><CRC><EOT>`
example: command: `<STX>FFCH148<EOT>`
response: `<STX>FFCH<ACK>1D<EOT>`
activates the reading head mode

command: `<STX>FFCH047<EOT>`
response: `<STX>FFCH<ACK>1D<EOT>`
activates the stand alone mode

10.3.3 Transponder number (T)

description: This command is used for a single reading of a transponder number held close to the antenna.
If there is no transponder close to the antenna the reader response will be NOTAG.
The transponder number will be sent as 10 HEX character ASCII code (e.g. AC3F00D1B4).

Format: `<STX><ADR>CT<CRC><EOT>`
example: command: `<STX>FFCT23<EOT>`
response: `<STX>FFCT03C2208CFF64<EOT>`
reads transponder number 03C2208CFF.

11 Application Examples

Example door opener:

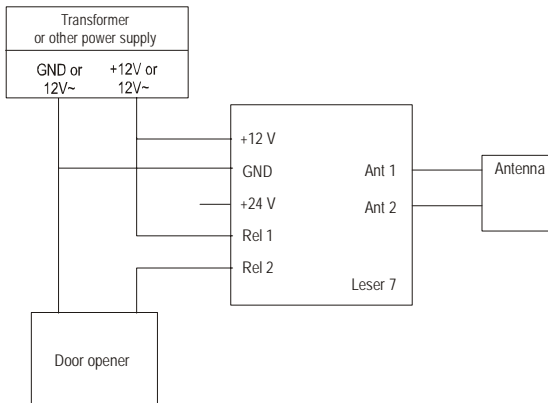

Example garage door control:

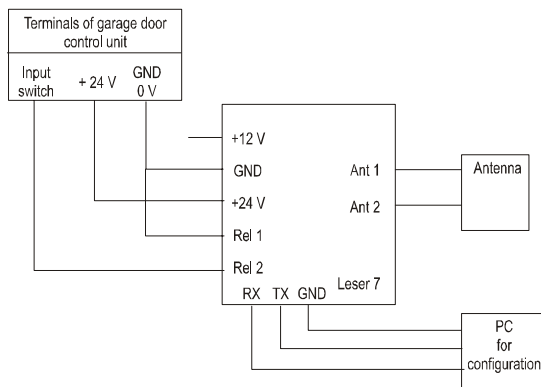

Please take care of correct connections according to the operation manual of the garage door control unit. Some devices may require different connecting of the input switch.
Set the relay switch time of the Leser 7 to 0,5 sec, for quickly toggling between UP and DOWN movement of the garage door.

12 Care, Maintenance and Disposal

Besides providing the specified voltage and its intended use as a device for acquisition, storage and interpretation of Transponder Data the Standalone Reader does not require any special care or maintenance.

An RF Reader that highly unexpected has become unusable must be disposed of observing all relevant legal regulations.

13 Debugging

If all notes and regulations of this and other relevant Operation Manuals (Online Help, etc.) are observed correctly there should be no unexpected malfunctions. If this nevertheless happens to be the case, please do not attempt to make any own repairs. Return the device to your point of purchase and have it checked and possibly repaired by a qualified engineer. Opening or improper handling of the devices will invalidate any guarantee.

14 Technical Specifications

Operation voltage:	7V to 30V DC. 7V to 20V AC
Current consumption:	max. 100 mA (at 12V)
frequency:	125 kHz
relay output:	3A / 30VDC, 3A / 125VAC
OpenCollector-Outputcurrent:	max. 100 mA, bei Ausgang 6: max. 200 mA,
OpenCollector-Total-Outputcurrent:	max. 500 mA
Max. reading distance:	app. 7 cm
Max. Distance Antenna / Electronics:	1.5 m
Max. number of Transponders:	100 key transponder
Max. number of events recorded:	2500
Measurements Casing (L x W x T):	125x75x28mm
Operating Temperature:	0°C bis 45°C

15 Notes on Manufacturer

CODATEX Heinzlmaier GmbH & Co. KG
Ischlerbahnstraße 15
A – 5020 Salzburg

Email: info@codatex.com
Internet: <http://www.codatex.com>



We herewith declare, that this RF reader is in accordance with the basic specifications and other relevant regulations of the directive 1999/5/EG.

The original declarations of conformity (Nr.: GOM20208-7058-C) can be found on our homepage under www.codatex.com.