

OPERATION MANUAL

Version 01/08



RF Reader Standalone Reader 6 Plus



Package Contents:

- Readerboard (case optionally)
- Operation Manual

Important! Read by all means!

To maintain the perfect shipping conditions and to ensure safe operation please observe the instructions in this Operation Manual. Damages caused by non-observance of these instructions will invalidate any guarantee. We further cannot take liability for any consequential damages.

Table of Contents

	Page
1. Introduction	3
2. Intended Use.....	3
3. Safety Instructions	3
4. Device Description	4
5. Functional Description	4
6. Connections	4
7. Putting into Operation	4
8. Operation.....	5
9. Applications	6
10. Care, Maintenance and Disposal	7
11. Debugging	7
12. Technical Specifications.....	7
13. Notes on Manufacturer.....	7

1. Introduction

Dear Customer,

We want to thank you for purchasing this Standalone Reader.

With this unit you have acquired a product built to the latest state of engineering. Its operation is simple and easily understood. Nevertheless please read this Operation Manual carefully for optimum utilization of all of its features.

2. Intended Use

The intended use of this Standalone Reader is the acquisition of transponder data by use of an Antenna Module. These data will be compared by the Standalone Reader with the transponder data stored in an internal EEPROM. If any one of the stored transponder numbers is recognized the Reader will switch an output. Any use other than the one pointed out above is not admissible.

Design and construction of this Module correspond to all European and national requirements for Electro Magnetic Compatibility (EMC). The unit carries the CE-Sign, the conformity has been proven. All appropriate commentaries and records are in the possession of the manufacturer.

3. Safety Instructions

Important Informations on the Reader Module:

- In conjunction with the Reader Module the Antenna builds a tank circuit creating high voltage at the antenna terminals. Please avoid any contact to these antenna terminals during operation of the Reader and especially keep children at a safe distance from the device.
- The RF Reader Family has not been designed to safely lock or secure doors. During prolonged absence from any room made accessible by a Reader the door must therefore further be locked by means of the original key.
- In order to guarantee sabotage safe operation do in any case mount the Reader's electronic circuit - unreachable for non-authorized persons - inside of the building.
- We cannot take liability for damages caused by improper and/or careless handling of RF Reader products.

For use with the RF Readers specific Transponders suitable for these Readers are necessary.

Notes on Installation of the Reader Modules:

- The Modules are considered Reading and Controlling Devices of Mode of Operation Typ 1 according to EN 60730 (VDE 0631).
- When installing the Reader and Antenna Modules ensure a clean and dry environment.
- The individual Modules must be dry and free of dust.
- For protection of the power supply line use a slow-acting 2.5 A fuse.
- In case a bell transformer is used to provide the necessary power to the Reader Modules of the RF Reader it has to correspond with the requirements according to EN 61558-2-8 (DIN VDE 0570 Part 2-8: Special requirements for bell and ringer transformers).

Notes on Placing and Mounting the Reader Modules:

When mounting Reader and Antenna the following guidelines have to be observed:

- Metallic objects must not be placed between Antenna and Transponder.
- The Antenna should be mounted on non-metallic material (wood, concrete) at a minimum distance of 3 cm from any metallic object.
- The connecting line of the Antenna must not be of any length in excess of 1.5 m. Otherwise the reading distance stated for the Reader Modules in Section 12. **Technical Specifications** cannot be guaranteed.
- The connecting line of the Antenna must not be mounted in the immediate proximity of any other line carrying electric current.
- Two or more connecting lines of any Antennas must not be mounted side by side.
- **When mounting several RF Readers inferences of Modules among each other can be avoided if a minimum distance of approximately 1 m is kept between Reading devices.**

4. Device Description

The Standalone Reader 6 Plus is an RF Reader designed to open doors or garage gates. It is housed in a compact casing. By use of an integrated relay door openers can directly be operated. To open garage gates the Reader can be operated on 24 VDC by use of a separate input. Example circuits for the Reader can be found in Section 9. **Applications.**

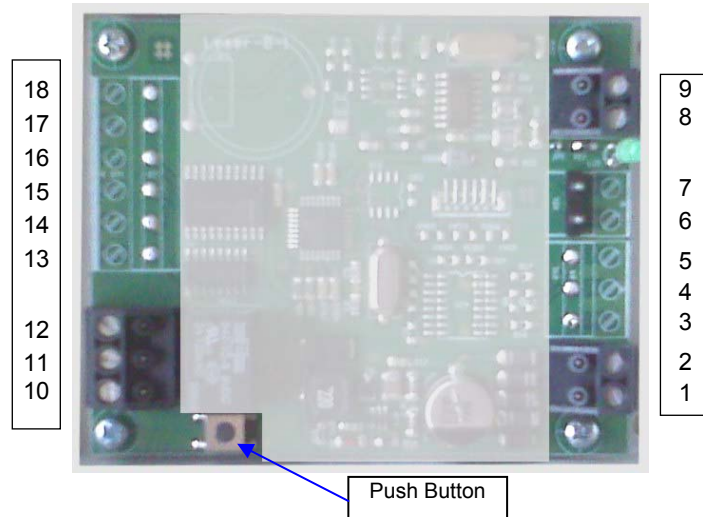

Printed Circuit Board: Standalone Reader 6plus
Terminal Positions

1. AC2 (7 to 30V DC, 7 to 20V AC)	10. Relay NC (Normally Closed)
2. AC1 (7 to 30V DC, 7 to 20V AC)	11. Relay NO (Normally Open)
3. nc	12. Relay COM (Common)
4. nc	13. nc
5. nc	14. nc
6. GND (for external push button)	15. nc
7. Push Button Input (internally connected to +5V with a 10k pull up)	16. nc
8. ANT2	17. nc
9. ANT1	18. nc

5. Functional Description

The Standalone Reader is an RF Reader which is able to store up to 99 Transponder Numbers in an internal EEPROM. When during acquisition of the transponder data the Transponder recognizes a stored number the Reader will switch a relay (NOC - normally open contact). The switching time of the relay can be set from 0.5 s to 14 s, whereby above 1 s the steps are at consecutive 1 s steps. At delivery a switch time of 0,5 sec is set.

The Transponders (Key Transponders) assigned to initiate a switching action ("open") are stored in EEPROM by use of a Master Transponder. Master Transponder can be any "normal" Transponder that is stored in EEPROM as a Master Transponder by use of a push button. Up to 3 Master Transponder can be stored in the reader.

A detailed description of this process can be found in Section 8. **Operation** further down.

6. Connections

The Reader can be operated on up to 30V DC. In normal Reading Mode the Reader consumes a current of less than 50 mA while during relay switching the current consumption rises to appr. 75 mA. The Reader's PCB measures 84 x 68 x 20 mm (L x W x H).

7. Putting into Operation

After the Standalone Reader and the Antenna have been connected in accordance with the connection scheme the Reader can be put into operation.

To do so switch on the Reader's power supply:

After activating the power supply the Reader is in permanent Reading Mode.

8. Operation

- **Programming the Master Transponder**

When configuring the Reader at first the Master Transponder has to be programmed. Up to 3 Master Transponders can be stored.

Programming condition for the Master Transponder is initiated by pressing the push button until the LED lights up and switches off again (appr. 1 s). Now the push button is to be released and the Master Transponder must be brought close to the Antenna. The recognition of the Master Transponder is then acknowledged by a three-fold lighting up of the LED. Up to 3 Master Transponder can be stored within this programming process.

The Reader is in programming condition for the Master Transponder for a maximum time period of 5 seconds. If during this length of time no Transponder is brought close to the Antenna, the Reader will acknowledge this process by a five-fold lighting up of the LED followed by a return of the Reader to the Reading Mode.

By programming Master Transponders all "old" Master Transponders are deleted.

The previously as Master Transponder stored Transponder is only empowered to program further Key Transponders. It cannot be stored as a Key Transponder.

A Master Transponder cannot be used for normal opening action.

Please mark your Master Transponder accordingly and keep it in a safe place.

- **Storing of a new Master Transponder**

In case the Master Transponder is lost, new Transponders can be stored as Master Transponders. This process will invalidate the previous Master Transponders.

If a Transponder used as Key Transponder is newly programmed to be Master Transponder it will lose its function as a Key Transponder.

Previously stored Key Transponders will remain in the Reader's memory, i. e. they will not be deleted by programming a new Master Transponder.

- **Programming of Key Transponders**

In order to program new Key Transponders the previously stored Master Transponder has to be brought close to the Antenna for read-in for at least 3 but no more than 10 seconds. The Reader will then change to the Programming Mode for 10 seconds. This condition is signalled by a two-fold short lighting up of the LED.

Depending on, if a read transponder has been programmed already as a key transponder, it will be either deleted or stored in the memory.

Every recognized and stored Key Transponder will be acknowledged by a single short lighting up of the LED. If an already stored transponder is deleted the LED will light up slightly longer.

SUMMARY: - Short LED light up means transponder stored as valid key.

- Longer LED light up means: valid transponder deleted from memory.

The 10 second time period for the programming mode will at times be newly started upon recognition of a Key Transponder.

A Transponder previously stored as Master Transponder cannot be used as a Key Transponder.

- **Adding of Key Transponders**

If any Master Transponder is being read for more than 3 but less than 10 seconds, the Reader will change to the programming condition and all Transponders previously stored in the Reader will remain valid.

By doing this new Transponder numbers can be added and stored as Key Transponders to the numbers already existing.

- **Erasing all stored Key Transponders**

If the Master Transponder is held close to the Antenna for longer than 10 seconds, the Reader will delete all stored Transponders and will change to the programming condition. The LED will light up twice after 3 seconds and twice again after 10 seconds. Then the Reader will start new programming of the Key Transponders.

Single Transponders cannot be erased separately.

Caution: When putting the unit into operation for the first time its memory should be erased completely, i. e. the Master Transponder should be brought close to the Antenna for at least 10 seconds.

- **PULSE Mode, ON/OFF Mode and Setting the Switching Time for the Relay**

The Reader allows the setting of the relay's switching time. During this process no Transponder must be close to the Antenna.

In order to set the switching time of the relay press the push button for at least 5 seconds until the LED lights up for the second time (immediately after pressing the push button the LED will light up. It will switch off again after about 1 second indicating the programming condition for the Master Transponder).

After the second lighting up of the LED release the push button and press it again as many times as the number of seconds you want to set the relay's switching time, i. e. the push button has to be pressed 3 times for a switching time of 3 seconds and accordingly 5 times for a 5 second switching time. The maximum switching time in PULSE Mode is 14 seconds. When pressing the push button the LED will switch off and will light up again when the push button is released. This way the number of push button strokes can also be counted optically. After the switching time has been set, press the push button until the LED shortly lights up three times, indicating the end of the setting process. The setting process for the relay's switching time has thus been concluded.

For setting the ON/OFF Mode you have to press the push button more often than the allowed 15 times. The switch time of the relay in ON/OFF Mode is unlimited. The relay will change its state every time a valid transponder is read at the antenna.

In order to set the shortest possible switching time of 0.5 seconds shortly release the push button after appr. 5 seconds, i. e. after lighting up of the LED and press and hold it again until the LED lights up 3 times.

Moreover the switching time of the relay is automatically extended as long as a valid Key Transponder is in the close proximity of the Antenna's reading area. This means that the set switching time only counts from that point in time when the transponder is removed from the reading area of the Antenna.

- **Memory Display**

It is possible to store up to 99 Key Transponders in the Reader.

In case the memory is completely filled (99 Key Transponders), the Reader will indicate this condition with a five-fold lighting up of the LED whenever an attempt to program further Transponders is started.

- **Reading Mode**

Whenever a transponder is read by the Reader its number is compared with the numbers of the Key Transponders stored in memory. If the particular number is present in memory, the relay is switched for the preset period of time. At the same time the LED lights up for the duration of the switching process.

9. Applications

Circuit Example: Door Opener

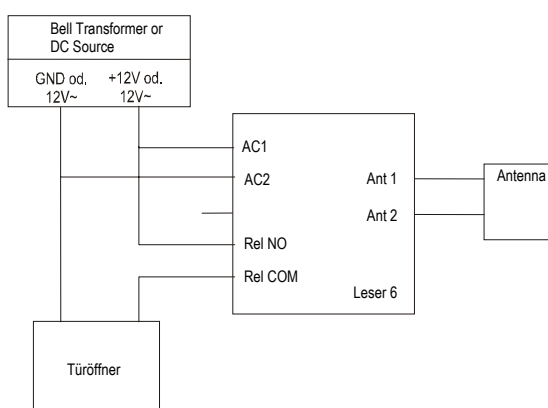

Circuit Example: Garage Gate Drive

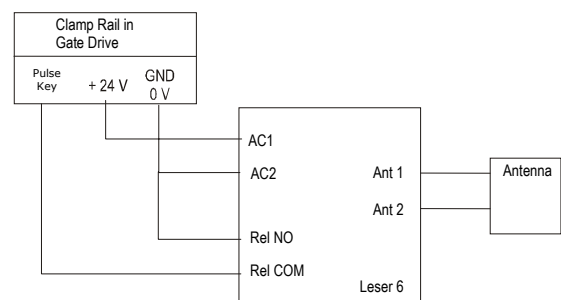

Mind the correct connection of the connecting lines as shown in the description of the garage gate drive. Further check whether or not the push button – as seen in the example – must really be keyed to GND.

Set the switching time to 0.5 s in order to be able to quickly toggle the gate movement between Up and Down.

10. Care, Maintenance and Disposal

Besides providing the specified voltage and its intended use as a device for acquisition, storage and interpretation of Transponder Data the Standalone Reader does not require any special care or maintenance.

An RF Reader that highly unexpected has become unusable must be disposed of observing all relevant legal regulations.

11. Debugging

If all notes and regulations of this and other relevant Operation Manuals (Online Help, etc.) are observed correctly there should be no unexpected malfunctions. If this nevertheless happens to be the case, please do not attempt to make any own repairs. Return the device to your point of purchase and have it checked and possibly repaired by a qualified engineer. Opening or improper handling of the devices will invalidate any guarantee.

12. Technical Specifications

Operating Voltage Reader Module	: 7 to 30V DC, 7 to 20V AC,
Power Consumption Reader Module	: max. 100 mA
Transmitter Frequency	: 125 kHz
Relay Switching Capacity (1 x m/b)	: 3A / 30VDC, 3A / 125VAC
Max. Reading Distance	: appr. 7 cm
Max. Distance Antenna / Electronics	: 1.5 m
Max. Number of Transponders	: 99 Key Transponders, 3 Master Transponder
Measurements Casing (L x W x T)	: 125 x 75 x 28 mm
Operating Temperature	: 0°C to 45°C

13. Notes on Manufacturer

CODATEX Hainzmaier GmbH & Co.KG
Ischlerbahnstraße 15
A – 5020 Salzburg

Email: info@codatex.com
Internet: <http://www.codatex.com>



We herewith declare, that this RF reader is in accordance with the basic specifications and other relevant regulations of the directive 1999/5/EG.

The original declarations of conformity (Nr.: G0M20208-7058-C) can be found on our homepage under www.codatex.com.